

(No Model.)

4 Sheets—Sheet 1.

P. GERSTENKORN.  
MACHINE FOR GRINDING COCKS.

No. 480,258.

Patented Aug. 9, 1892.

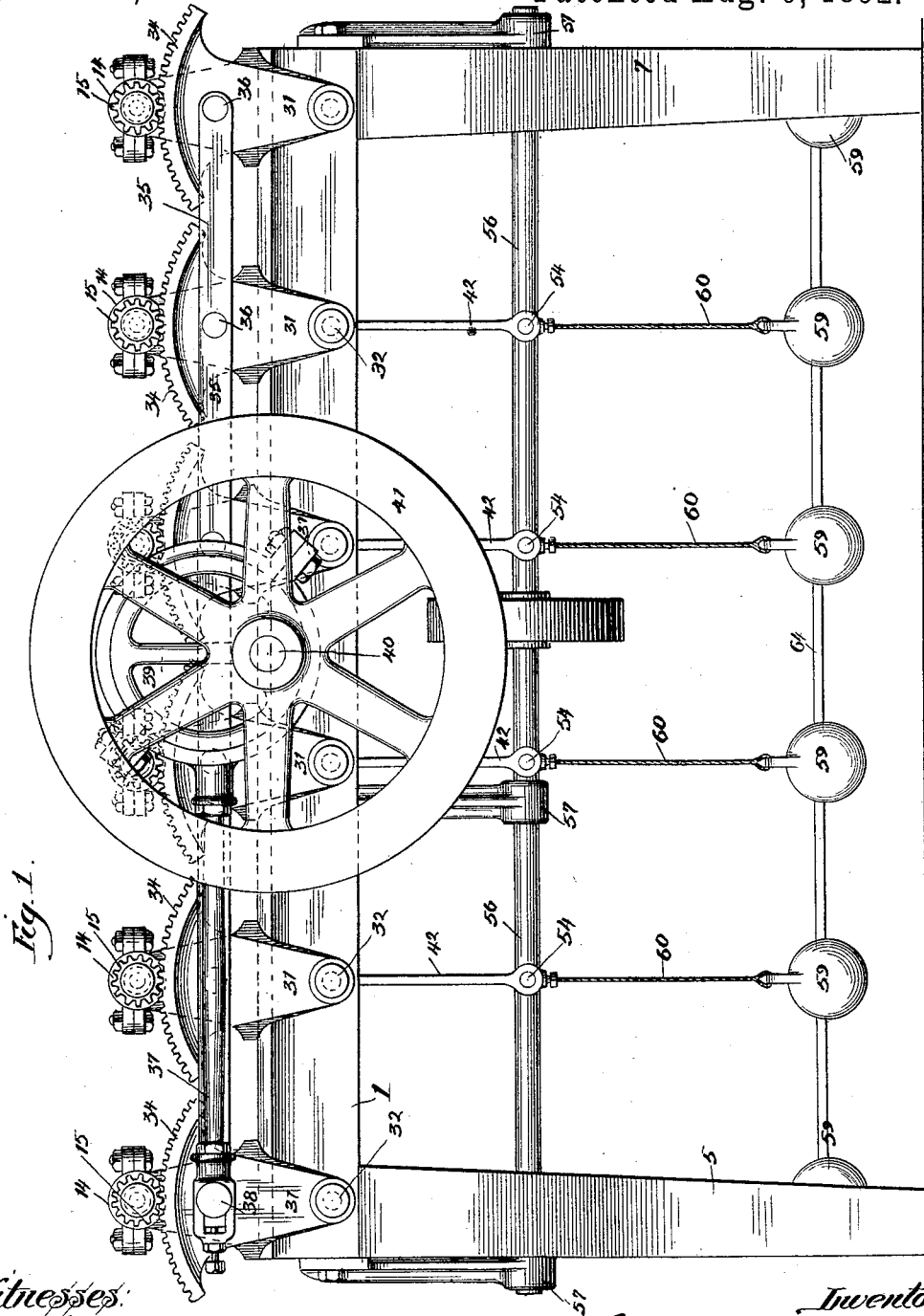

Fig. 1.

Witnesses:  
 John L. Jackson.  
 Nellie McKibben.

Inventor:  
 Paul Gerstenkorn  
 by Bond Adams & Howard  
 Attorneys

(No Model.)

4 Sheets—Sheet 2.

# P. GERSTENKORN. MACHINE FOR GRINDING COCKS.

No. 480,258.

Patented Aug. 9, 1892.

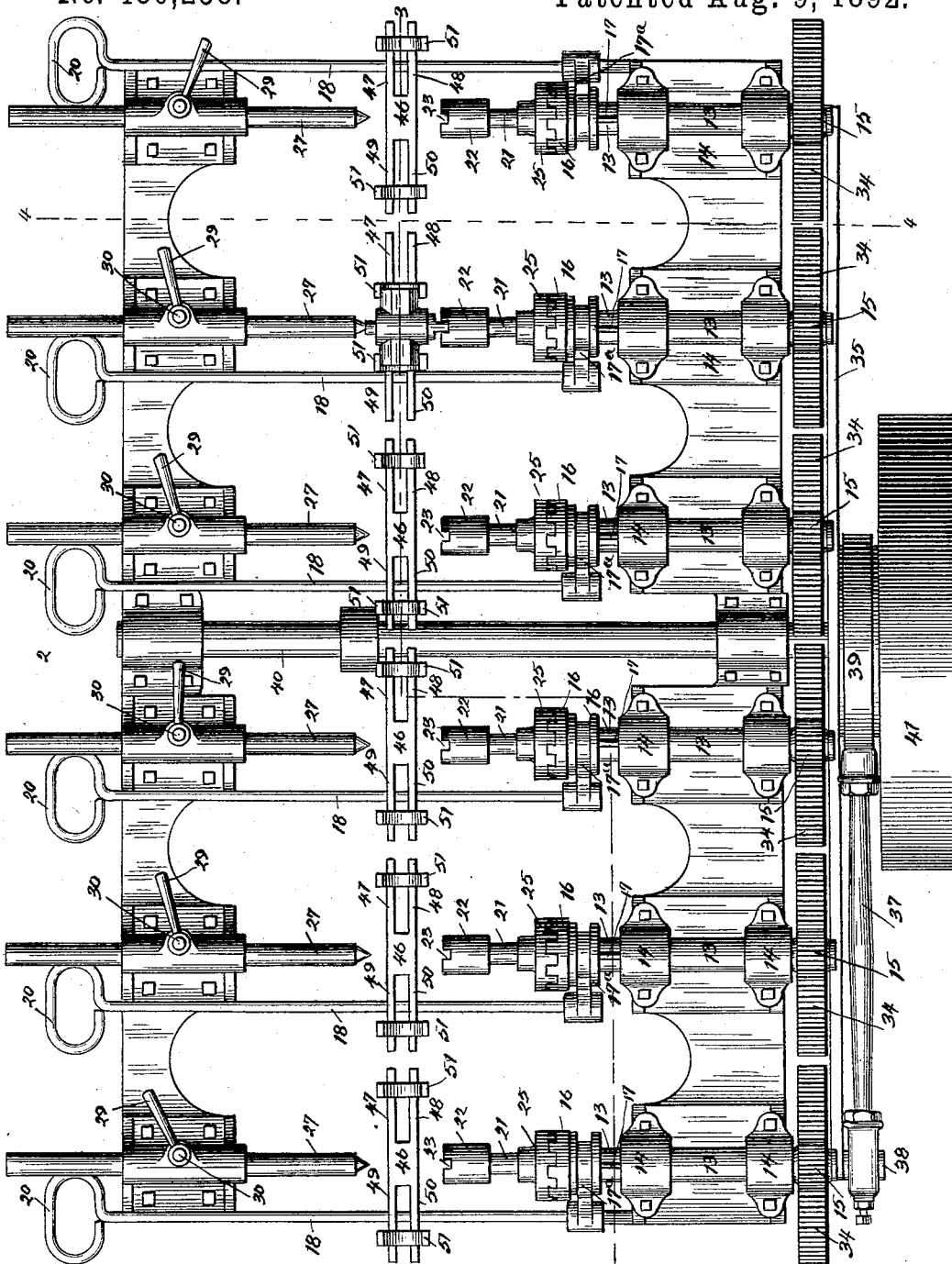

Witnesses:  
*John L. Jackson.*  
*Kellie McKibben*

*Fig. 2*

Inventor:  
*Paul Gerstenkorn*  
 by *Burd, Adams & Howard*  
 Attorneys.

P. GERSTENKORN.  
MACHINE FOR GRINDING COCKS.

No. 480,258.

Patented Aug. 9, 1892.

Fig. 3.

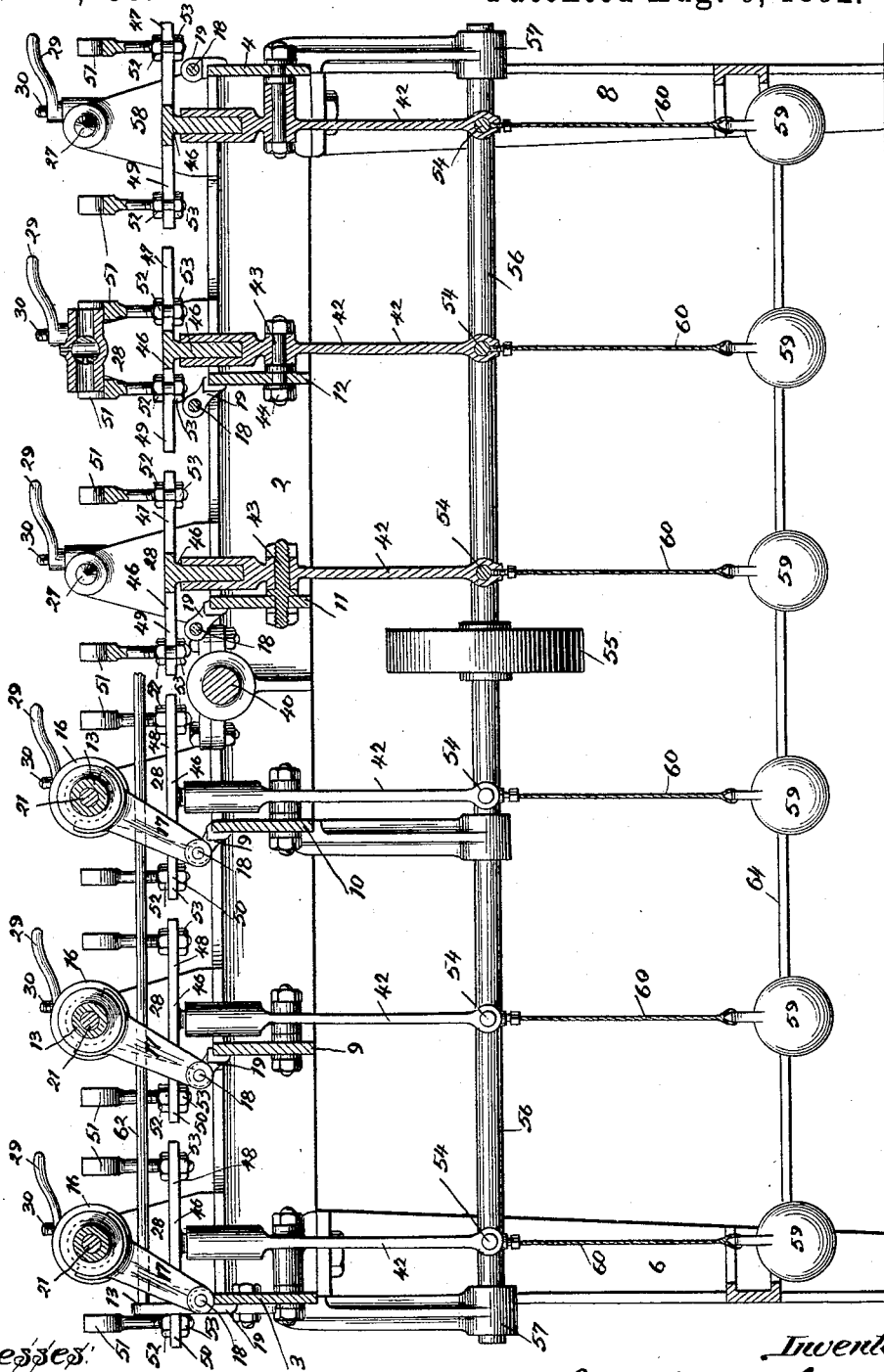

Witnesses:  
 John L. Jackson.  
 Nellie Mc Kibben

Inventor:  
 Paul Gerstenkorn  
 by Bond, Adams & Pickard  
 Attorneys

(No Model.)

4 Sheets—Sheet 4.

P. GERSTENKORN.  
MACHINE FOR GRINDING COCKS.

No. 480,258.

Patented Aug. 9, 1892.

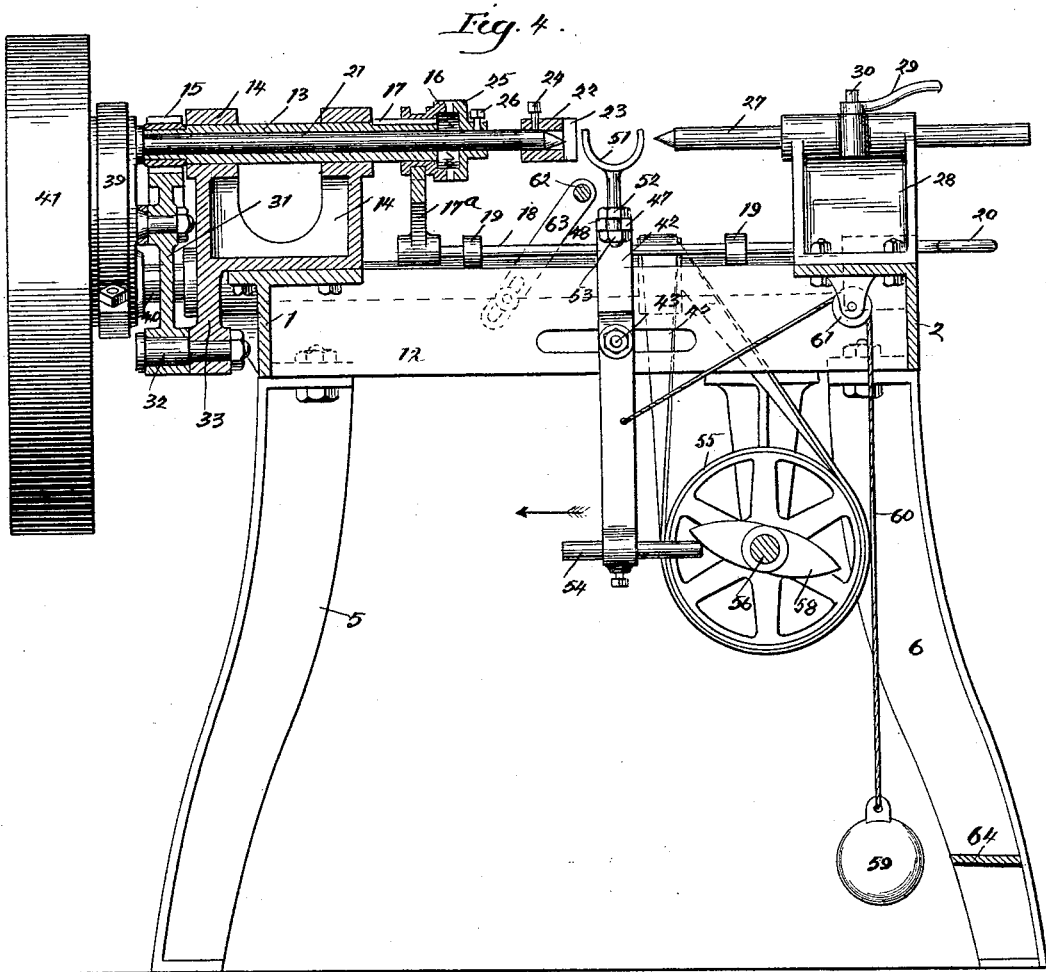

Witnesses:

John L. Jackson.  
Kellie McKibben

Inventor:

Paul Gerstenkorn  
by Bond, Adams & Pickard  
Attorneys

# UNITED STATES PATENT OFFICE.

PAUL GERSTENKORN, OF MILWAUKEE, WISCONSIN, ASSIGNOR TO HIMSELF,  
AND OTTO BUDDE, OF CHICAGO, ILLINOIS.

## MACHINE FOR GRINDING COCKS.

SPECIFICATION forming part of Letters Patent No. 480,258, dated August 9, 1892.

Application filed February 6, 1892. Serial No. 420,595. (No model.)

*To all whom it may concern:*

Be it known that I, PAUL GERSTENKORN, a subject of the Emperor of Germany, residing at Milwaukee, in the county of Milwaukee and State of Wisconsin, have invented certain new and useful Improvements in Machines for Grinding Cocks, of which the following is a specification, reference being had to the accompanying drawings, in which—

Figure 1 is a side elevation. Fig. 2 is a top or plan view. Fig. 3 is a longitudinal vertical section on line 3 3 of Fig. 2, and Fig. 4 is a vertical cross-section on line 4 4 of Fig. 2.

My invention relates to machines for grinding the keys of cocks in their seats; and the principal object of my invention is to provide a new and improved machine by which a number of cocks may be ground simultaneously, and the parts of which will be so arranged that one operator may easily attend to the machine.

Another object of my invention is to improve the construction and operation of such machines in general.

I accomplish these objects as hereinafter specified, and as illustrated in the drawings.

That which I regard as new will be pointed out in the claims.

In the drawings, 1 2 indicate the side portions of the frame which support the various parts of the machine; 3 and 4, the end portions; and 5, 6, 7, and 8, legs which support the frame 1 2 3 4.

9 10 11 12 indicate cross-pieces extending transversely across the frame of the machine, serving to strengthen the frame and to support the various parts of the machine.

I prefer to use a frame constructed as above described; but I do not wish to limit myself to the exact arrangement shown.

The machine shown in the drawings is adapted to grind six cocks at a time; and it consists of six similar devices for holding and grinding the cocks, all operated by a common driving mechanism. As the parts of each section are similar, I will describe the construction and operation of a single one, it being understood that the operation of the others is the same. The different sections are also similarly numbered. A machine may be used having any desired number of sections, as the

operation is entirely independent of the number of sections. Each section consists of the following parts:

13 indicates a sleeve which is suitably journaled upon a bracket 14, mounted upon the side 1 of the supporting-frame in such position that the sleeve 13 will extend transversely of the frame. The outer end of the sleeve 13 projects beyond the outer edge of the bracket 14 and is provided with a cogged pinion 15, as best shown in Figs. 1 and 4. The inner end of the sleeve 13 projects a short distance beyond the inner end of the bracket 14 and is provided with one-half of a clutch 16, as best shown in Fig. 4. The half-clutch 16 is adapted to slide upon a feather 17, fixed longitudinally in the sleeve 13, as best shown in Fig. 4, by which construction the half-clutch 16 may be moved longitudinally upon said sleeve.

17<sup>a</sup> indicates a rod which is connected to the rear portion of the half-clutch 16, as best shown in Figs. 3 and 4, and extends downward, as shown.

18 indicates a connecting-rod mounted in suitable guides 19, supported in the frame of the machine, which rod extends to the side 2 of the frame, beyond which it projects, where it is provided with a handle 20, as shown in Fig. 2. By moving the rod 18 transversely of the frame the half-clutch 16 may be shifted longitudinally upon the sleeve 13, for purposes which will be hereinafter set forth.

21 indicates a shaft which is mounted in the sleeve 13, as best shown in Fig. 4, and is provided on its free end with a block 22, having a slot 23, adapted to receive the top of the cock-key. The block 22 is adjustably secured upon the end of the shaft 21 by means of a set-screw 24, as best shown in Fig. 4. The end of the shaft 21 is pointed to adapt it to serve as a lathe-center for holding the cock-key.

25 indicates the half of a clutch, which half is secured upon the shaft 21 by means of a set-screw 26, as best shown in Fig. 4, and is adapted to engage the half-clutch 16. The arrangement is such that when the half-clutches 16 and 25 are in contact with each other and the sleeve 13 is oscillated the oscillating motion will be communicated to the shaft 21.

27 indicates a shaft mounted in a suitable bracket 28 in such manner that it will lie parallel to and opposite the shaft 21. The shaft 27 is pointed and serves as the other lathe-center for holding the cock-key.

29 indicates a lever mounted upon a screw 30, which is mounted in the bracket 28 and is adapted to bear against the shaft 27 to hold it in position. By operating the lever 29 the shaft 27 may be adjusted so that the distance between the lathe-centers may be regulated as desired.

31 indicates a segmental plate which is mounted at its lower end upon a shaft 32, suitably journaled in a depending portion 33 of the bracket 14, as best shown in Fig. 4. The upper portion of the plate 31 is cogged to form a rack 34, as best shown in Fig. 1, which rack intermeshes with the pinion 15, carried by the sleeve 13, as best shown in Figs. 1 and 4. By oscillating the plate 31 the pinion 15 will alternately be rotated in opposite directions, and the shaft 21 will also be similarly rotated when the half-clutches 16 and 25 are in engagement with each other. A similar segmental plate 31, having a rack 34, is provided for each section of the machine, as shown in Fig. 1, and in order that all the segments may be operated from a common source of power the following apparatus is provided.

35 indicates a connecting-rod, which is pivotally connected to each segment 31 near its upper end by means of pins 36.

37 indicates a pitman, one end of which is connected to a pin 38 upon one of the segments 31, as shown in Fig. 1, the other end being operated by an eccentric 39, mounted upon a shaft 40, which carries a band-wheel 41, as shown. By this construction by operating the wheel 41 all the segments 31 will be rocked.

42 indicates a swinging lever which carries the devices for holding the cock-seat, which lever 42 is pivotally mounted upon a shaft 43, which projects from one of the cross-bars 9, 10, 11, or 12, or the end-plates 3 4, as best shown in Fig. 3. The shaft 43 is secured in place upon its supporting-plate by means of a nut 44 and passes through a slot 45 in its supporting-plate, as best shown in Fig. 4. By loosening the nut 44 the position of the shaft 43 upon the plate may be changed to throw the pivotal point of the lever 42 toward one side or the other of the machine, as may be necessary. The lever 42 carries a cross-head 46, which is arranged horizontally upon the upper end of the lever 42 and is provided with arms 47 48 49 50, as best shown in Fig. 2.

51 indicates perpendicular brackets, one of which is mounted upon each side of the cross-head 46, the lower end of each bracket 51 being secured between the arms 47 48 or 49 50 by means of nuts 52 53, one above and the other below the cross-head. By this construction the two brackets 51 upon the cross-head may be moved toward or from each

other. The upper ends of the brackets 51 are suitably hollowed out to adapt them to receive and hold loosely an ordinary cock-seat.

The lower end of the lever 42 projects downward a considerable distance beyond the shaft 43, and is provided on its lower end with a tappet 54, as best shown in Fig. 4.

55 indicates a pulley which is mounted upon a shaft 56, which is longitudinally mounted in suitable bearings 57 at opposite ends of the machine and extends longitudinally of the machine. The pulley 55 is operated from the shaft 40 by means of a belt or other suitable gearing.

58 indicates a cam which is mounted upon the shaft 56 and is of about the shape shown in Fig. 4, being approximately elliptical. The arrangement of the cam 58 is such that when rotated it will at suitable intervals strike the tappet 54 and cause the lower portion of the lever 42 to move in the direction indicated by the arrow in Fig. 4, thereby throwing the upper portion of the lever 42 and the seat carried by the brackets 51 in an opposite direction. The object of this construction will be more fully hereinafter set forth.

59 indicates a counterpoise which is connected by means of a rope or cable 60, which passes over a pulley 61, to the lower portion of the lever 42, as best shown in Fig. 4. The counterpoise thereby acts to return the lever 42 to its perpendicular position after the cam 58 has moved away from the tappet 54.

62 indicates a bar which extends longitudinally of the machine a short distance below and to one side of the brackets 51, as shown in part in Fig. 3, which bar serves to limit the motion of the seat-supporting levers in one direction. The rod 62 is supported upon suitable brackets 63, which are adjustable, as shown by dotted lines in Fig. 4.

The operation of my machine is as follows: The seat of the cock is loosely placed in the brackets 51, carried by each cross-head 46, after which a key is passed through the seat and is supported between the centers of the shafts 21 and 27, the top of the key being fitted into the slot 23 in the block 22. The machine is then set in operation and the rod 20 is operated to throw the half-clutches 16 and 25 into engagement with each other. By this means the key will be alternately rotated in opposite directions in the seat and will thereby be ground to fit closely into the seat. The cam 58 is so arranged that at suitable intervals in its rotation it will strike the tappet 54 and move the lever 42, as hereinbefore described, thereby withdrawing the seat from the key a short distance to bring fresh bearing-surfaces in contact with the key after the seat is returned to its position upon the key by the operation of the counterpoise 59. The weight of the counterpoise may be changed in order to hold the seat upon the key with greater or less pressure. If it is desired to throw any one cock out of operation without stopping the machine, by operating the rod

20 the half-clutches 16 and 25 may be thrown out of engagement with each other and the grinding of any one cock be stopped.

By the construction herein shown the grinding devices are arranged compactly and are so placed and operated that a large number may be controlled by a single operator. The sections are also practically independent of each other, so far as throwing them into and out of operation is concerned.

64 indicates a shelf, which extends longitudinally of the machine at a height slightly above the weights 59. When not in use, the weights may be placed on the shelf to remove the strain from the supporting-ropes.

That which I claim as my invention, and desire to secure by Letters Patent, is—

1. The combination, with a number of seat-supporting devices, of a corresponding number of shafts adapted to support keys in the seats, a sleeve carried upon each of said shafts, mechanism for operating said shafts from said sleeves, pinions carried by said sleeves, segmental rack-plates intermeshing with said pinions and adapted to be oscillated to operate said pinions, a connecting-rod connecting said rack-plates, and means for reciprocating said connecting-rod, substantially as and for the purpose specified.

2. The combination, with a number of seat-supporting devices, of a corresponding number of shafts adapted to support keys in the seats, a sleeve carried upon each of said shafts, mechanism for operating said shafts from said sleeves, pinions carried by said sleeves, segmental rack-plates intermeshing with said pinions and adapted to be oscillated to operate said pinions, connecting-rod connecting said rack-plates, pitman 37, eccentric 39, and band-wheel 41, substantially as and for the purpose specified.

3. The combination, with a key-holder, means for oscillating the same, and a seat-holder for holding a cock-seat upon a key, of a lever-and-cam mechanism which intermittently vibrates the seat-holder and moves the seat off of and upon the key at regular intervals during the grinding operation to present fresh surfaces of the seat to the action of the oscillating key, substantially as described.

4. The combination, with a key-holder, means for oscillating the same, and a seat-holder for holding a cock-seat upon a key, of automatically operating mechanism which vibrates the seat-holder and moves the seat off of and upon the key at regular intervals during the grinding operation to present fresh surfaces of the seat to the action of the oscillating key, substantially as described.

5. The combination, with a key-holder and means for oscillating the same, of a laterally-adjustable shaft 43, a lever 42, mounted on the shaft and provided with a cock-seat holder, a cam operating upon the lever to intermittently vibrate the same and thereby move the cock-seat off of and upon the key at regular intervals during the grinding operation to present

fresh surfaces of the cock-seat to the action of the oscillating key, and devices for adjusting the lever-supporting shaft for the purpose of varying the lateral throw of the lever at will, substantially as described.

6. The combination, with a supporting-frame having a plate 31 and slot 45 in said plate, shaft 43, mounted in said slot, lever 42, mounted upon said shaft, nuts 44 for securing said shaft in said slot, and seat-holding devices carried by said lever, of key-holding devices carried by said frame and means for rotating said key-holding devices alternately in opposite directions, substantially as and for the purpose specified.

7. The combination, with a series of cock-seat holders, of a corresponding number of shafts for supporting keys in the cock-seats, a sleeve carried upon each shaft, means for operating the shafts from the sleeves, pinions mounted on the sleeves, oscillating segmental rack-plates engaging the pinions, a rod connecting the rack-plates, means for operating the rod to simultaneously oscillate the rack-plates, and a lever-and-cam mechanism which intermittently vibrates the cock-seat holders to move the cock-seats off of and upon the keys at regular intervals during the grinding operation to present fresh surfaces of the seats to the action of the oscillating keys, substantially as described.

8. The combination, with key-holding devices and means for rotating them alternately in opposite directions, of a transversely-swinging lever, means for transversely swinging said lever, seat-holding brackets carried by said lever, and means for adjusting said brackets with relation to each other, substantially as and for the purpose specified.

9. The combination, with key-holding devices and means for rotating them alternately in opposite directions, of a transversely-swinging lever, means for transversely swinging said lever, cross-head carried by said lever, brackets 51, carried by said cross-head, and means for adjusting said brackets with relation to each other, substantially as and for the purpose specified.

10. The combination, with key-holding devices and means for rotating them alternately in opposite directions, of a transversely-swinging lever, means for transversely swinging said lever, cross-head 46, carried by said lever, said cross-head having arms 47 48 49 50, brackets 51, carried by said cross-head, and nuts 52 and 53 upon said brackets, substantially as and for the purpose specified.

11. The combination, with a supporting-frame and seat-holding devices mounted therein, of a sleeve mounted transversely upon said frame, means for rotating said sleeve alternately in opposite directions, a shaft mounted in said sleeve, means for operating said shaft from said sleeve, and key-holding devices carried by said shaft, substantially as described.

12. The combination, with a supporting-frame and seat-holding devices carried there-

by, of a sleeve 13, means for rotating said sleeve alternately in opposite directions, a half-clutch 16, mounted upon said sleeve, means for operating said half-clutch 16, a shaft 21, mounted in said sleeve, a half-clutch 25, carried thereby, means for rigidly securing said half-clutch 25 thereupon, and key-holding devices, substantially as and for the purpose specified.

10 13. The combination, with a supporting-frame and seat-holding devices carried thereby, of a sleeve 13, means for rotating said sleeve alternately in opposite directions, a half-clutch 16, mounted upon said sleeve, 15 means for operating said half-clutch 16, a shaft 21, mounted in said sleeve, a half-clutch 25, carried thereby, means for rigidly securing said half-clutch 25 thereupon, block 22, mounted upon the end of said shaft, slot 23 20 in said block, and shaft 27, adjustably mounted in the frame of the machine opposite said shaft 21, substantially as and for the purpose specified.

14. The combination, with a supporting- 25 frame and seat-holding devices carried thereby, of a sleeve 13, means for rotating said sleeve alternately in opposite directions, a half-clutch 16, mounted upon said sleeve, rod 17, connected to said half-clutch 16, rod 18, 30 suitably mounted in the frame of the machine, a shaft 21, mounted in said sleeve, a half-clutch 25, carried thereby, means for rigidly

securing said half-clutch 25 thereupon, block 22, mounted upon the end of said shaft, slot 23 in said block, and shaft 27, adjustably 35 mounted in the frame of the machine opposite said shaft 21, substantially as and for the purpose specified.

15. The combination, with a supporting-frame, of a transversely-swinging lever 42, 40 seat-holding devices carried by said lever, tappet 54 on the lower end of said lever, shaft 56, cam 58, mounted thereupon and adapted to engage the tappet 54, means for rotating said shaft 56, counterpoise 59, pulley 61, cord 60, 45 passing over said pulley and connected to the lower portion of the lever 42, a sleeve 13, having a gear-wheel 15, segmental rack-plate adapted to be oscillated to rotate said sleeve alternately in opposite directions, means for 50 oscillating said rack-plate, half-clutch 16, carried by said sleeve and movable longitudinally thereupon, means for moving said half-clutch, shaft 21, mounted in said sleeve, half-clutch 25, carried thereby and adapted to be 55 engaged by the half-clutch 16, and a shaft 27, mounted in the frame of the machine opposite and parallel to the shaft 21, substantially as and for the purpose specified.

PAUL GERSTENKORN.

Witnesses:

OTTO BUDDE,  
JOHN L. JACKSON.